

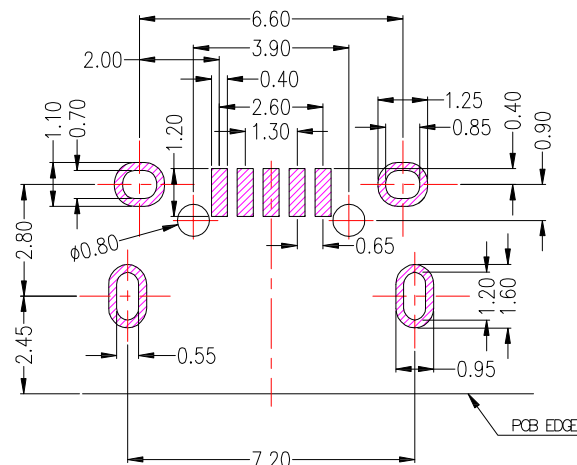

# MRUSB-5BED14Bx-S347

SHELL 鍍層:

TN
NI

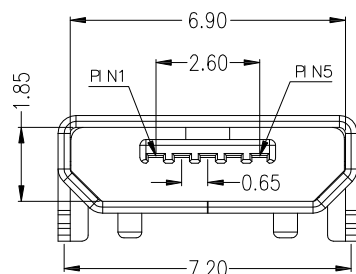
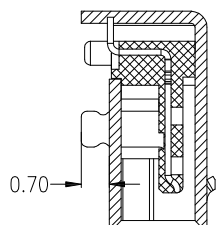
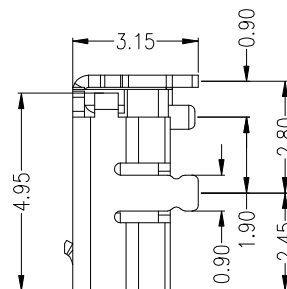
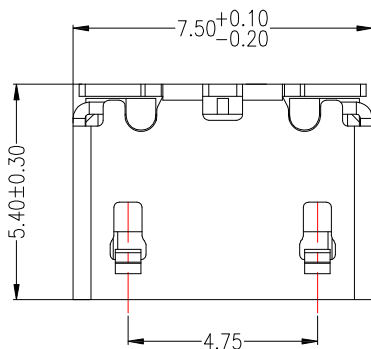
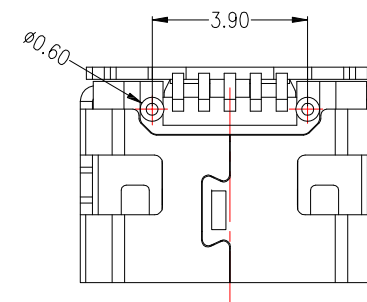
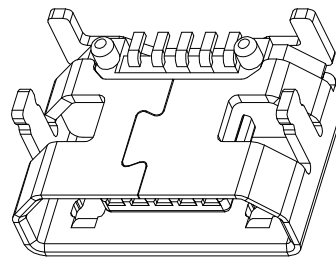
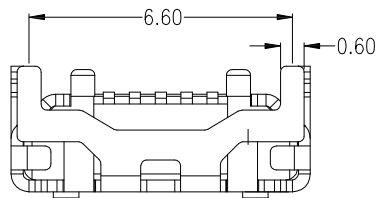

P.C.B LAYOUT MOUNTING PATTERN

NOTES:

1.MATERIAL:

- 1.1 HOUSING: LCP
- 1.2 CONTACT: PHOSPHOR BRONZE
- 1.3 SHELL: SUS

2.Finish:

- 2.1 Contact: Plated Gold in Mating Area ;  
Gold Plated on Solder Balls ;  
Nickel under plated overall
- 2.2 Shell: Tin or Nickel under Plated surface layer

3.SPECIFICATION:

- 3.1 CURRENT RATING: 1.8 A (PIN1,5) ; 1.0 A(PIN2,3,4)
- 3.2 DIELECTRIC WITHSTANDING VOLTAGE: 100 V(ac) FOR 1min
- 3.3 CONTACT RESISTANCE: 30 mΩ MAX.
- 3.4 INSULATION RESISTANCE: 100 MΩ MIN.
- 3.5 TOTAL MATING FORCE: 3.57 Kgf MAX.
- 3.6 TOTAL UNMATING FORCE: 1.0 Kgf MIN.
- 3.7 TEMPERATURE RANGE: -30°C ~ +80°C

**CONTACT** 建倚科技股份有限公司  
CONTACT TECHNOLOGY CORP.

TOLERANCE UNLESS OTHERWISE STATED:  
Up to 5 ±0.2  
Above 5 ~ 15 ±0.3  
Above 15 ~ 30 ±0.4  
Above 30 ~ 50 ±0.5  
Angle ±0.3

3RD. ANGEL'S



UNITS

MM

DRAWN BY: Jack Lu  
CHECKED BY: Jacky Chen  
APPROVED BY: Tony Kao

DATE: 08/02/18  
DATE: 08/02/18  
DATE: 08/02/18

MAT'L		TITLE	CONNECTOR
FINISH		MODLE	MICRO USB 5BF 牛角(PH7.2-6.6) 有柱,無捲邊
SCALE	1 : 1	DWG NO.	MRUSB5B-ED14Bx-S347
SHEET NO.	1 of 1	PART NO.	MRUSB5B-ED14Bx-S347
		SIZE	A4
		VER	R

ITEM NO.	DESCRIPTION	DRAWN	DATE